



**BUCYRUS-ERIE**

# 90-XC

## HYDROCRANE®

### 90 TON HYDRAULIC TRUCK CRANE

### PRELIMINARY SPECIFICATIONS

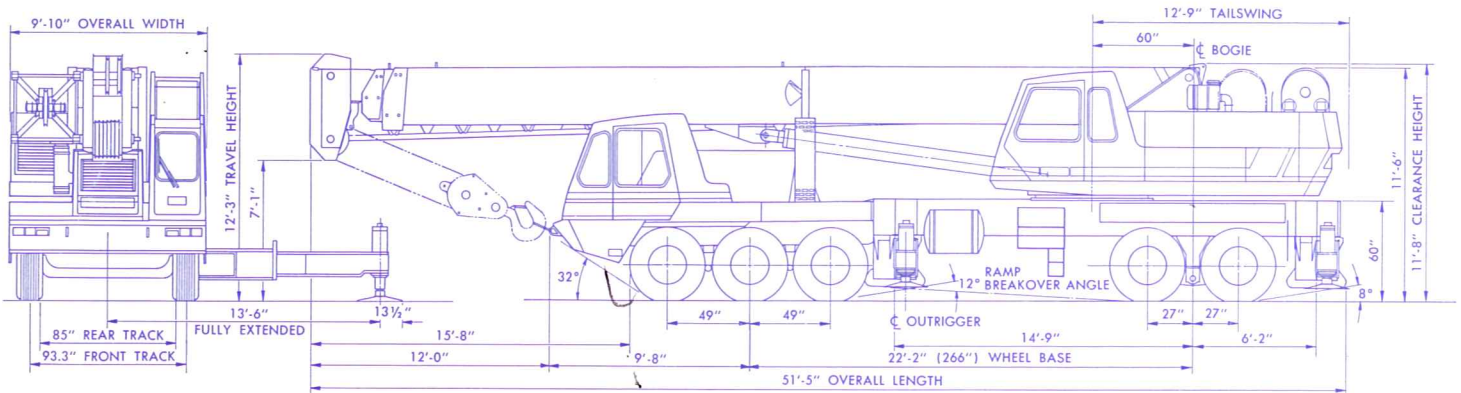

883259

HOIST DRUMS													
				Normal Range				High Range				Rope Capacity	
				Low Line Pull		High Line Pull		Low Line Pull		High Line Pull			
Hoist Unit	Lagging	Layer Of Rope	Pitch Diameter (Inches)	Max. Line Pull (Lbs.)	Max. Line Speed (FPM)	Max. Line Pull (Lbs.)	Max. Line Speed (FPM)	Max. Line Pull (Lbs.)	Max. Line Speed (FPM)	Max. Line Pull (Lbs.)	Max. Line Speed (FPM)	With Controlled Free Fall (Feet)	Without Controlled Free Fall (Feet)
Main or Auxiliary* B-E Model 20 3/4" Rope	Standard	1st	16.75	15,800	195	19,200	95	7,900	390	9,600	185	127	153
		2nd	18.25	14,500	210	17,700	100	7,200	425	8,800	205	265	320
		3rd	19.75	13,400	230	16,300	110	6,700	460	8,100	220	415	501
		4th	21.25	12,400	245	15,200	120	6,200	495	7,600	235	576	695
	High Speed	1st	23.50	11,200	275	13,700	130	5,600	550	6,800	260	186	224
		2nd	25.00	10,600	290	12,900	140	5,300	585	6,400	280	376	453
Auxiliary B-E Model 10 5/8" Rope	Standard	1st	11.25	7,800	395	9,500	190	—	—	—	—	74	93
		2nd	12.50	7,000	435	8,600	210	—	—	—	—	157	196
		3rd	13.75	6,400	480	7,800	230	—	—	—	—	248	309
		4th	15.00	5,900	525	7,100	250	—	—	—	—	347	433
	High Speed	1st	17.44	5,000	610	6,100	290	—	—	—	—	115	144
		2nd	18.69	4,700	650	5,700	315	—	—	—	—	238	298

\*Only normal range available on model 20 auxiliary hoist unit.

ENGINE SPECIFICATIONS — UPPER							
Make	Model	Type	Cylinders	Bore x Stroke (Inches)	Displacement (Cubic Inches)	Horsepower (S. A. E. Gross)	Max. Altitude (Feet)
Detroit Diesel	6V53N	Diesel	6	3 7/8 x 4 1/2	318	197 at 2800 RPM	4,000
Cummins	V-504C	Diesel	8	4 5/8 x 3 3/4	504	185 at 2800 RPM	4,000

# 90-XC HYDROCRANE® 90 TON HYDRAULIC TRUCK CRANE

PCSA 0-354

MAXIMUM ALLOWABLE LOADS — CRANE SERVICE* — WITH COUNTERWEIGHT																			
WEIGHT OF HOOKS, HOOK BLOCKS, SLINGS, JIBS AND ALL OTHER LOAD HANDLING DEVICES, EXCEPT THE HOIST ROPE, SHALL BE CONSIDERED PART OF THE LOAD.																			
BOOM LENGTH IN FEET																			
Load Radius In Feet	42.5			56			72			88			104			144			Load Radius In Feet
	Boom Angle In Degrees	Boom Point Pin Height (Ft.—In.)	Out-riggers Set* Load In Pounds	Boom Angle In Degrees	Boom Point Pin Height (Ft.—In.)	Out-riggers Set* Load In Pounds	Boom Angle In Degrees	Boom Point Pin Height (Ft.—In.)	Out-riggers Set* Load In Pounds	Boom Angle In Degrees	Boom Point Pin Height (Ft.—In.)	Out-riggers Set* Load In Pounds	Boom Angle In Degrees	Boom Point Pin Height (Ft.—In.)	Out-riggers Set* Load In Pounds	Boom Angle In Degrees	Boom Point Pin Height (Ft.—In.)	Out-riggers Set* Load In Pounds	
10	74.3	50-11	180,000																10
12	71.4	50-1	164,300	76.0	64-5	143,000													12
15	66.9	48-10	138,400	72.8	63-5	130,000	76.8	80-3	99,300										15
20	59.0	45-7	105,600	67.2	61-3	105,600	72.6	78-7	82,700	75.9	95-5	69,500							20
25	50.2	41-5	83,200	61.4	58-5	84,300	68.3	76-7	72,400	72.4	93-10	58,100	75.2	110-8	49,700				25
30	39.9	35-6	58,400	55.1	54-11	59,400	63.8	74-1	60,000	68.9	91-10	49,000	72.3	109-0	41,900	76.4	150-8	29,750	30
35	25.6	26-2	43,900	48.3	50-5	44,900	59.2	71-0	45,400	65.3	89-6	42,500	69.4	107-1	36,000	74.3	149-4	25,800	35
40				40.5	44-8	35,400	54.3	67-5	35,900	61.6	86-9	36,200	66.4	104-10	31,500	72.2	147-10	22,800	40
50				15.9	22-11	23,700	43.2	57-9	24,300	53.7	79-10	24,500	60.1	99-5	24,400	68.4	144-2	18,700	50
60							28.7	42-6	17,300	44.8	70-7	17,600	53.9	92-4	17,700	64.0	139-7	15,050	60
										34.1	57-5	13,000	46.6	83-3	13,100	59.5	134-0	12,700	70
										19.8	34-8	9,700	38.1	71-3	9,900	54.7	127-4	10,650	80
													27.3	53-10	7,400	49.6	119-5	8,700	90
																44.2	109-9	7,050	100
																38.1	99-0	5,500	110
																31.0	84-3	4,200	120
																21.9	63-10	3,150	130

835315

### CRANE SERVICE

Maximum Allowable Loads shown apply only to machines with all components in first class condition built or recommended by Bucyrus-Erie Company.

Maximum Allowable Loads are based on freely suspended loads with the machine leveled and standing on a firm, uniform supporting surface. Practical working loads depend on supporting ground, the effect of shock or side loading, wind, and other factors affecting stability, hazardous surroundings, experience of personnel and proper handling, all of which must be taken into account by the operator.

Maximum Allowable Loads are based on components and conditions shown under "LIMITATIONS" and "MACHINE EQUIPMENT".

Maximum Allowable Loads are in accordance with P.C.S.A. Standard #2.

Load Radius is the horizontal distance from the axis of rotation before loading, to the center of the vertical hoist line or tackle with load applied.

### LOAD RATING DEDUCT DATA

Weight of hooks, hook blocks, slings, jibs, and all other load handling devices, except the hoist rope, shall be considered part of the load.

Maximum Allowable Loads on main boom sheaves must be reduced 2,650 lbs. when lifting over the main boom with manual swing-around extension attached to boom point; Jibs — Maximum Allowable Loads must be reduced as follows:

Jib	When Lifting Over Main Boom With Swing-Around and Jib Attached	When Lifting Over Swing-Around With Jib Attached
24 Foot	4,500 lbs.	3,250 lbs.
39 Foot	4,950 lbs.	3,550 lbs.
54 Foot	5,400 lbs.	3,900 lbs.

### LIMITATIONS

#### Main and Aux. Hoist Unit (Model #20): Hoist Tackle

For Loads Over (lbs.)	15,000	30,000	45,000	60,000	75,000	90,000
Parts of Line	2	3	4	5	6	7
	105,000	120,000	135,000	150,000	165,000	
	8	9	10	11	12	

#### Auxiliary Hoist Unit (Model #10): Hoist Tackle

For Loads Over (lbs.)	7,500	15,000	22,500	30,000	37,500	45,000
Parts of Line	2	3	4	5	6	7
	52,500	60,000	67,500	75,000	82,500	
	8	9	10	11	12	

#### Swing-Around Hoist Tackle

For loads over 15,000 pounds use 2 parts of line.

#### Jib Load Rating

For Maximum Allowable Loads on jibs, refer to separate Jib Load Rating Chart.

#### Boom Telescope

Maximum Allowable Load which may be telescoped is limited by boom angle, hydraulic pressure, and boom lubrication. Boom sections must be extended equally at all times.

#### Machine Weight

Maximum Allowable Load ratings are based on a machine having a minimum front axle loading of 43,000 lbs. and a minimum rear axle of 61,500 lbs. with the boom in the boom rack, and counterweight attached to upper works.

### MACHINE EQUIPMENT

11,000 lbs. removable counterweight.

#### Carrier

266 in. W.B.—9 ft. 10 in. wide 10 x 4 semi-low profile cab carrier with hydraulic outriggers to 27 ft. 0 in. spread.

#### Wire Rope

Main and Auxiliary Hoist (Model #20) 3/4" dia., 6 x 25, IWRC, 51,200 lbs. minimum breaking strength.

Auxiliary Hoist (Model #10) 3/4" dia., 8 x 19, EIPS, IWRC, 36,200 lbs. minimum breaking strength.

For complete wire rope specifications and reeving, refer to instruction manual for this machine.

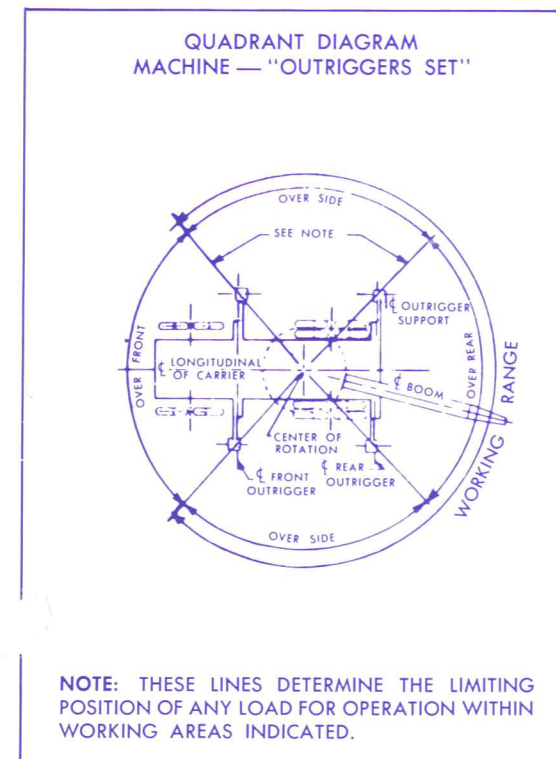

**NOTE:** THESE LINES DETERMINE THE LIMITING POSITION OF ANY LOAD FOR OPERATION WITHIN WORKING AREAS INDICATED.

#### "OUTRIGGERS SET"

See quadrant diagram "OUTRIGGERS SET". These are the Maximum Allowable Loads which can be lifted, Over the Side or Over the Rear. This machine must always be operated with the outriggers fully extended and set to a distance of 27 feet 0 inches between centerlines of the float connections with all tires clear of the ground.

DO NOT lift or swing loads within the quadrant designated Over Front.

Maximum Allowable Loads shown in shaded area are limited by factors other than tipping.

Crane Loads do not exceed 85% of the tipping loads with the machine leveled and standing on a firm, uniform supporting surface.

**CAUTION:** DO NOT LIFT LOADS, EXTEND BOOM, OR SWING MACHINE WITHOUT OUTRIGGERS FULLY SET.

**CAUTION:** LONG CANTILEVER BOOMS CAN CREATE A TIPPING CONDITION WHEN IN EXTENDED AND LOWERED POSITION. WHERE NO LOAD IS SHOWN ON THE LOAD RATING CHART AT A GIVEN RADIUS, TIPPING CONDITION SHALL BE ASSUMED TO EXIST.

**CAUTION:** USE OF JIB IS LIMITED TO MACHINES WITH COUNTERWEIGHT PROPERLY ATTACHED TO REAR OF CRANE.

# 90-XC HYDROCRANE® 90 TON HYDRAULIC TRUCK CRANE

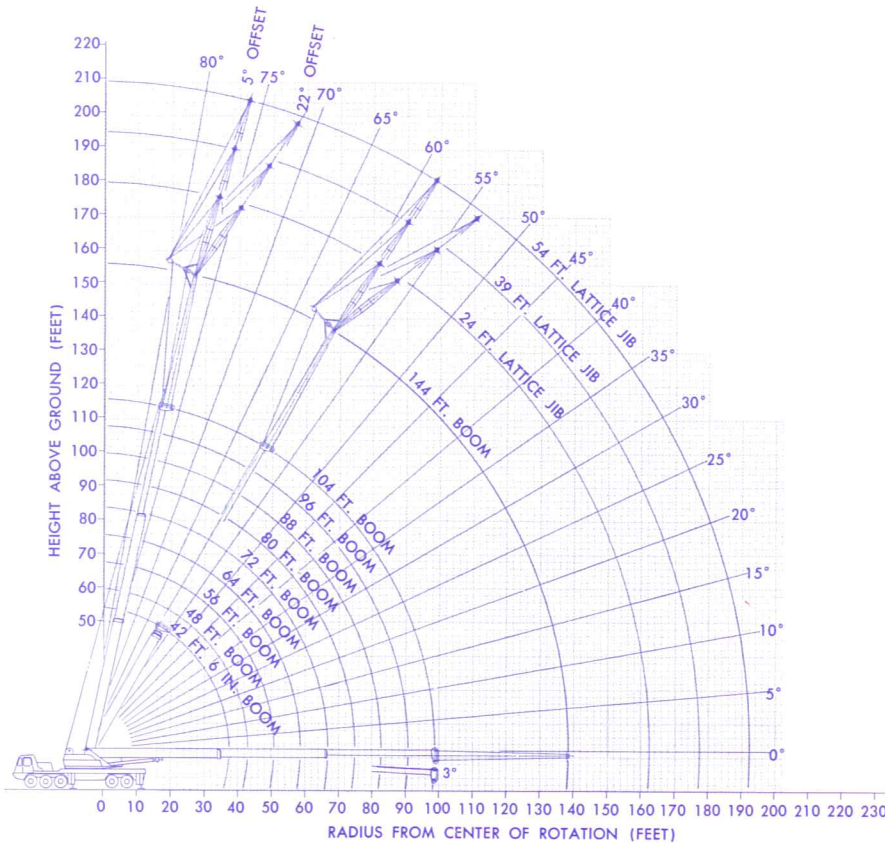

HOOK BLOCKS			
Capacity	No. Sheaves	No. Parts Line	'Y' Dim.
90 Ton	6	1-12	72 In.
20 Ton	1	1-3	65 In.
8.5 Ton	—	1	45 In.

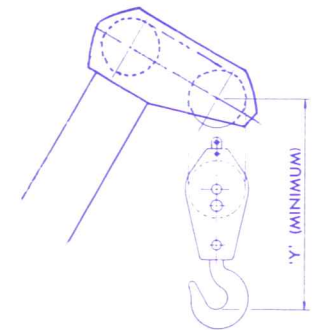

887049

MAXIMUM ALLOWABLE LOADS — JIB SERVICE WITH COUNTERWEIGHT						
WEIGHT OF HOOKS, HOOK BLOCKS, SLINGS, AND ALL OTHER LOAD HANDLING DEVICES, EXCEPT THE HOIST ROPE, SHALL BE CONSIDERED PART OF THE LOAD.						
OUTRIGGERS SET* — LOAD IN POUNDS						
Jib Length In Feet						
Boom Angle In Degrees	24		39		54	
	5° Offset**	22° Offset**	5° Offset**	22° Offset**	5° Offset**	22° Offset**
80	20,000	15,000	15,000	10,000	10,000	7,500
75	14,500	12,400	12,250	8,300	8,000	6,700
70	11,750	10,500	10,250	7,200	6,800	5,900
65	10,000	9,000	8,750	6,200	5,800	5,100
60	8,500	7,750	7,350	5,300	5,000	4,400
55	7,000	6,500	6,300	4,500	4,150	3,700
50	6,000	5,500	5,300	3,800	3,400	3,100
45	5,100	4,900	4,400	3,100	2,800	2,550
40	4,000	3,900	3,500	2,550	2,300	2,100
35	3,150	3,000	2,800	2,150	1,900	1,750
30	2,500	2,400	2,050	1,800	1,650	1,600

\*See "OUTRIGGERS SET" note, page 6. 746580

\*\*"Offset" — Angular offset centerline of boom to centerline of jib.

Maximum Allowable Loads shown in shaded area are limited by factors other than tipping.

**CAUTION: DO NOT OPERATE MACHINE WITH JIB ON BOOM POINT UNLESS THE MACHINE IS LEVELED AND STANDING ON A FIRM, UNIFORM SUPPORTING SURFACE WITH THE "OUTRIGGERS SET".**

**CAUTION: LONG CANTILEVER BOOMS CAN CREATE A TIPPING CONDITION WHEN IN EXTENDED AND LOWERED POSITION. DO NOT OPERATE AT BOOM ANGLES LOWER THAN SHOWN ON CHART.**

### JIB SERVICE

Maximum Allowable Loads shown apply only to machine with all components in first class condition built or recommended by Bucyrus-Erie Company.

Maximum Allowable Loads are based on freely suspended loads with the machine leveled and standing on a firm, uniform supporting surface. Practical working loads depend on supporting ground, the effect of shock or side loading, wind, and other factors affecting stability, hazardous surroundings, experience of personnel and proper handling, all of which must be taken into account by the operator.

Maximum Allowable Loads are based on components and conditions shown under "LIMITATIONS" and "MACHINE EQUIPMENT".

Maximum Allowable Loads are in accordance with P.C.S.A. Standard #2.

### LOAD RATING DEDUCT DATA

Weight of hooks, hook blocks, slings, and all other load handling devices, except the hoist rope, shall be considered part of the load.

When hook block is suspended on boom point sheave, the load over the jib point sheave must be reduced as follows:

24 ft. Jib	1100 lbs.
39 ft. Jib	1000 lbs.
54 ft. Jib	950 lbs.

When hook block is suspended on swing-around point sheave, the load over the jib point sheave must be reduced as follows:

24 ft. Jib	1550 lbs.
39 ft. Jib	1400 lbs.
54 ft. Jib	1300 lbs.

### LIMITATIONS

Required length of boom for lattice jib service is 144 feet. The boom must be fully extended, with swing-around section locked into working position on the boom point sheave pins.

Refer to "Crane Load Rating Chart" for other items that apply.

### MACHINE EQUIPMENT

Alloy steel tubular jib, 11,000 lb. counterweight, and pertinent equipment listed on "Boom Load Rating Chart".